

# Canon

## Macro Lenses

EF50mm f/2.5 Compact macro

EF100mm f/2.8 Macro

## Instructions

### Nomenclature

- ① Magnification scale (normal operation)
- ② Distance scale
- ③ Depth-of-Field scale
- ④ Magnification scale with Life Size Converter EF attached (EF50mm f/2.5 only)
- ⑤ Distance index
- ⑥ Focusing ring
- ⑦ Focus mode switch
- ⑧ Lens mount index
- ⑨ Contacts
- ⑩ Focusing distance range selector switch (EF100mm f/2.8 Macro only)

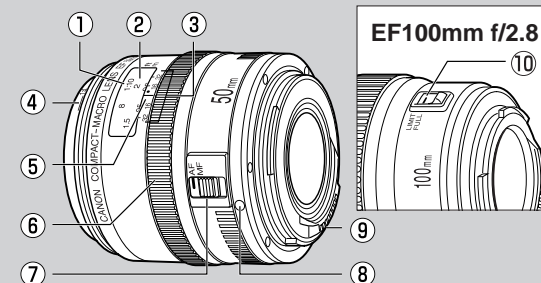

### Thank you for purchasing a Canon product.

The EF50mm f/2.5 Compact macro is a macro lens that can be used for standard shooting and for close-up shooting up to 1/2 x (0.5x). This is a standard macro lens for EOS cameras. Lifesize magnification (1x) is also possible by attaching the Life Size Converter EF sold separately. The Canon EF100mm f/2.8 Macro is a medium telephoto macro lens that provides life-size close-up capability.

#### ⚠ Safety Precautions

1. **Do not look at the sun or a bright light source through the lens or camera.** Doing so could result in loss of vision. Looking at the sun directly through the lens is especially hazardous.
2. **Whether it is attached to the camera or not, do not leave the lens under the sun without the lens cap attached.** This is to prevent the lens from concentrating the sun's rays, which could cause a fire.

#### ⚠ Handling Cautions

**If the lens is taken from a cold environment into a warm one, condensation may develop on the lens surface and internal parts.** To prevent condensation in this case, first put the lens into an airtight plastic bag before taking it from a cold to warm environment. Then take out the lens after it has warmed gradually. Do the same when taking the lens from a warm environment into a cold one.

### 1. Mounting and Detaching the Lens

See your camera's instructions for details on mounting and detaching the lens.

- After detaching the lens, place the lens with the rear end up to prevent the lens surface and contacts from getting scratched.
- If the contacts get soiled, scratched, or have fingerprints on them, corrosion or faulty connections can result. The camera and lens may not operate properly.
- If the contacts get soiled or have fingerprints on them, clean them with a soft cloth.
- If you remove the lens, cover it with the dust cap. To attach it properly, align the lens mount index and the O index of the dust cap, and turn clockwise. To remove it, reverse the order.

### 2. Setting the Focus Mode

To shoot in autofocus (AF) mode, set the focus mode switch to AF ③. To shoot in manual focus (MF) mode, set the focus mode switch to MF, and focus by turning the focusing ring.

- Do not touch the rotating parts of the lens while AF is active.

### 3. Switching the Focusing Distance Range (EF100mm f/2.8 Macro only)

**FULL:** Allows a focusing distance range of 0.31 m (Min. focusing distance) to ∞ for standard shooting ④.

**LIMIT:** Allows a focusing distance range of 0.31 m (life-size) to 0.57 m (0.25x) for close-up shots.

### 4. Close-up Photography (Macro Photography)

Close-up photos are possible up to 0.5x maximum magnification with the EF50mm f/2.5 Compact macro, and up to 1x (life-size) magnification with the EF100mm f/2.8 Macro. The focusing distance is the distance from the subject to the film plane.

When focusing, you can give priority to framing or to magnification.

#### [Framing Priority]

While looking through the viewfinder and framing the subject, focus with the AF or MF mode.

#### [Magnification Priority]

(1) **Set the lens' focus mode switch to MF.**

(2) **Set the magnification.**

While referring to the distance scale on the lens, turn the focusing ring to the desired magnification.

(3) **Focus the subject.**

While looking through the viewfinder, move the camera forward or back to find the point of focus.

(4) **Touch up the focus.**

Turn the focusing ring for fine focusing.

- Since macro shots have a very shallow depth of field, focus carefully to obtain proper sharpness.
- To prevent camera shake, using a Remote Switch and tripod is recommended (both sold separately).
- To check the depth of field, press the camera's depth-of-field preview button.

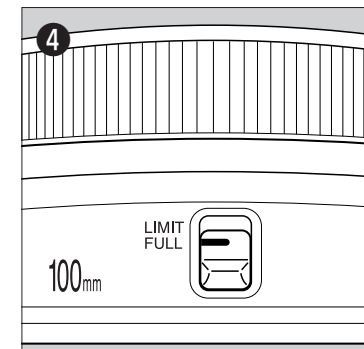
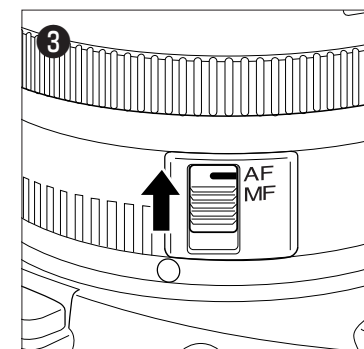
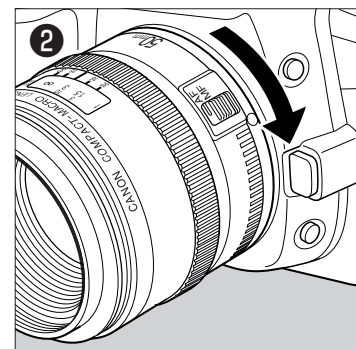
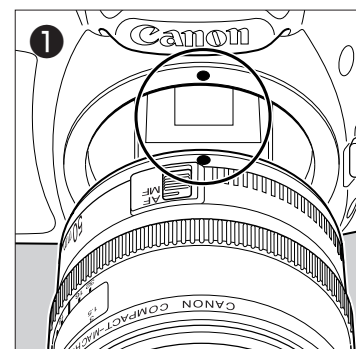

## 5. Setting the Exposure

When taking photographs using TTL metering, no exposure compensation is necessary to meter the light coming through the lens. With TTL metering, AE (autoexposure) is possible at all focusing distances. Just set the desired picture-taking mode, then check the shutter speed and aperture before taking the picture. When you use a handheld exposure meter to set the exposure, you must take into account the exposure factor shown in the following table.

### EF50mm f/2.5 Compact macro lens only

Magnification	1:10	1:8	1:6	1:5	1:4	1:3	1:2.5	1:2
Effective f/No.	1.21	1.27	1.36	1.44	1.56	1.78	1.96	2.25
Exposure Factor (stops)	in ½ stops	0		+½		+1.0		
	in ⅓ stops	0		+⅔		+1.0		

### EF50mm f/2.5 with Life Size Converter EF

Magnification	1:4	1:2	1:1.5	1:1.2	1:1
Effective f/No.	1.64	1.87	2.16	2.49	2.86
Exposure Factor (stops)	in ½ stops	+½	+1.0	+1½	
	in ⅓ stops	+⅔	+1.0	+1⅓	+1⅔

### EF100mm f/2.8 Macro

Magnification	1:4	1:3	1:2.5	1:2	1:1.5	1:1
Effective f/No.	1.44	1.61	1.76	1.99	2.41	3.38
Exposure Factor (stops)	in ½ stops	+½	+1.0	+1½	+2.0	
	in ⅓ stops	+⅔	+1.0	+1⅓	+1⅔	

- The correct exposure for a close-up shot largely depends on the subject. Therefore, it is recommended to take several shots of the same subject at different exposures.
- When taking close-up shots, it is recommended to use aperture-priority AE (Av) or Manual (M) picture-taking modes, because depth of field and exposure are easy to adjust in those modes.

## 6. Depth-of-Field Scale

The depth of field is the distance in front of and behind the plane of focus on the subject that appears sharp. The depth of field is indicated by the area between the depth-of-field scale lines below the distance scale. The numbers on the scale are F values (with the EF50mm f/2.5 Compact macro ⑤).

- The depth-of-field scale is an approximate indicator.

## 7. Infrared Index (EF50mm f/2.5 Compact macro only)

The infrared index corrects the focus setting when using monochrome infrared film. Focus on the subject in MF, then adjust the distance setting by moving the focusing ring to the corresponding infrared index mark ⑦ - (A), (B).

- Some EOS cameras cannot use infrared film. See the instructions for your EOS camera.

## 8. Filters

You can attach filters to the filter mounting thread on the front of the lens ⑦.

- Only one filter may be attached.
- Use a polarizing Canon filter (52 mm).

## 9. Specifications

	EF50mm f/2.5	EF100mm f/2.8
Focal Length/Aperture	50mm, f/2.5	100mm, f/2.8
Lens Construction	8 groups, 9 elements	9 groups, 10 elements
Angle of View	Diagonal-46° Vertical-27° Horizontal-40°	Diagonal-24° Vertical-14° Horizontal-20°
Focusing Distance Ranges	0.23 to ∞ m (0.58 to ∞ inch)	0.31 to ∞ m full (0.79 to ∞ inch) 0.31 to 0.57 m (0.8 to 0.14 inch) with limit 0.57 to ∞ m (1.45 to ∞ inch) with limit
Max. Magnification	0.5x/1x (with Life Size Converter EF attached)	1x
Filter Diameter	52 mm	
Max. Diameter and Length	67.6 × 63 mm (2.7 × 2.5 inch)	75 × 105.3 mm (3 × 4.1 inch)
Weight	280 g (9.8 oz)	650 g (1.42 lb)

- The lens length is measured from the mount surface to the front end of the lens. Add 21.5 mm to include the E-52 lens cap and dust cap, and 23.9 mm for the E-52 II.
- The size and weight listed are for the lens only, except as indicated.
- Aperture settings are specified on the camera.
- All data listed is measured according to Canon standards.
- Product specifications and appearance are subject to change without notice.
- Case and hood not provided with some models.
- Filters sold separately.

This device complies with Part 15 of the FCC Rules. Operation is subject to the following two conditions: (1) This device may not cause harmful interference, and (2) this device must accept any interference received, including interference that may cause undesired operation.

Do not make any changes or modifications to the equipment unless otherwise specified in the instructions. If such changes or modifications should be made, you could be required to stop operation of the equipment.

This equipment has been tested and found to comply with the limits for a class B digital device, pursuant to part 15 of the FCC Rules.

These limits are designed to provide reasonable protection against harmful interference in a residential installation. This equipment generates, uses and can radiate radio frequency energy and, if not installed and used in accordance with the instructions, may cause harmful interference to radio communications.

However, there is no guarantee that interference will not occur in a particular installation. If this equipment does cause harmful interference to radio or television reception, which can be determined by turning the equipment off and on, the user is encouraged to try to correct the interference by one or more of the following measures:

- Reorient or relocate the receiving antenna.
- Increase the separation between the equipment and receiver.
- Consult the dealer or an experienced radio/TV technician for help.

This Class B digital apparatus complies with Canadian ICES-003.

